

flow

PLUMBING IMPORTS LTD

Perfect Grind® Waste Disposal Unit



McALPINE
Plumbing Products

The plumbers' first choice. The market leader in plumbing products

Perfect Grind® Waste Disposal Unit

An environmentally sound solution to the growing problem of food waste



- 25% more torque than other brands provides more grinding power
- Unique permanent magnet motor produces higher RPM (revolutions per minute) than AC (Alternating Current) induction motors
- Corrosion proof cast stainless steel impellers on all models
- 180° dual swivel anti-jam impellers prevent jamming
- High efficiency performance saves time, water and energy
- Motor incorporates sound eliminating insulation technology for quiet operation
- Bioguard antimicrobial eliminates bacteria and odours
- Power cord included
- Supplied with 90° Bend x 40mm BSP thread for connection to trap



The plumbers' first choice. The market leader in plumbing products

Perfect Grind® Waste Disposal Unit



Perfect Grinding System

Perfect Grind® System can efficiently grind the toughest bones faster and finer than other brands and is safe for any properly sized septic system. Wear resistant and corrosion proof.

- Stainless steel, high precision, high speed dynamic balanced grinding turntable
- Stainless steel grinding rings
- Stainless steel, dual swivel anti-jam impellers prevent jamming
- Specially designed large opening, round holes and arch cutters



WDU-4ASNZ - Perfect Grind® continuous feed 1 1/4 HP Food Waste Disposer

Level	Entry
HP - RPM	1 1/4 HP - 2500 RPM
Warranty	10 Years
Fixing System	3 Bolt Mount
Grinding System	Stainless Steel
Switch	Wall Switch



E7788



Corrosion Proof Grinding Chamber

Grind chamber is constructed with the proven durability of glass filled nylon for lasting performance and is treated with BioGuard Antimicrobial Odour Protection.

Perfect Grind® Waste Disposal Unit

The plumbers' first choice. The market leader in plumbing products

Technical Specification

WDU-4ASNZ - Perfect Grind® continuous feed 1¹/₄ HP Food Waste Disposer

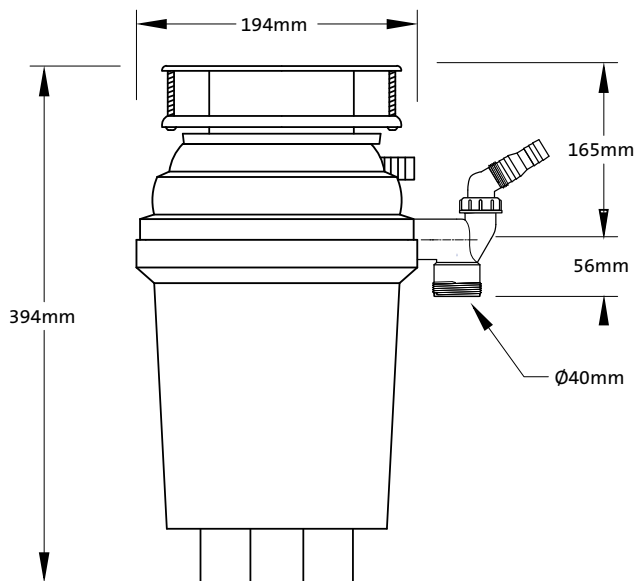

HP	1 ¹ / ₄
Motor Type	Permanent Magnet
Feed	Continuous
Volts	240V
Frequency	50/60Hz
Motor Speed	2500RPM
Hopper Capacity	857ml
Balance Level	G0.4
Turntable	Stainless Steel
Grind Rings	Stainless Steel
Sink Flange	Stainless Steel
Basket Strainer	Stainless Steel
Drain Elbow	ABS
Bearings	Permanently Lubricated, Sleeve Type
Manual Reset Protector	Protection for Overload and Temp

Flow Plumbing Imports Limited

24a Morrin Road, Mt Wellington, P.O. Box 14063 Panmure, Auckland 1741, New Zealand
Phone: +64 (0) 9 527 0037 Fax: +64 (0) 9 527 0038 0800mc Alpine www.flowimports.co.nz